

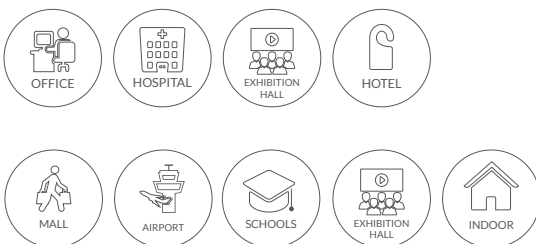

LED PL G24



The images are merely illustrative, some technical features and accessories may be changed without notice.



May 2019

Product Description

PL LED lamps are perfectly ideal as direct replacements whenever upgrading from obsolescent CFL technologies in a wide variety of interior lighting applications. The PL series, proudly produced exclusively by Teslights, are most frequently used for recessed applications, however they can also be used for all general lighting purposes with resplendent effect. In fact, a near-infinite variety exists among the compatible fixtures and bases in which Teslights PL lights may be advantageously installed.



Key Features

- **Modular manufacturing process**
- **5 year factory warranty**
- **No rewiring of fixture, minimizing replacement and maintenance cost**

Product Specifications

LED package:	SMD 2835 (0.2W)
Power consumption:	7-12W \pm 5%
Operating voltage:	100-277V AC 50/60Hz
Efficacy:	Up to 120lm/W
THD:	<18%
P.F.:	>0.90
CRI:	>80
Dimming:	NO
Material:	6063 aluminum heatsink and polycarbonate lens cover
Beam angle:	120°
Fire rating:	94VO
IP rating:	IP40
Operating temperature:	-25°C ~ +45°C

Product Measurement

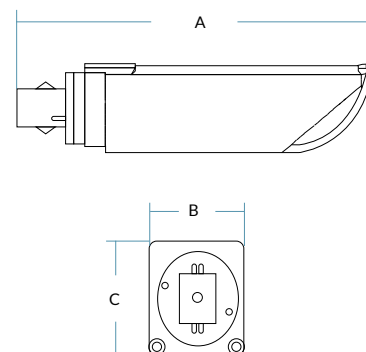

Model	Measures (AxBxC)
PL 7W / 9W / 12W	151 x 35 x 36 mm



Ordering Guide

example: PLS12M120C40

Type	Dim or non-dim	Watts	Driver/Power	Efficacy	Cover	CCT		
PL	S	12	M	120	C	40		
PL	S	Non-Dimmable	07 7W 09 9W 12 12W	M	Internal 100-277V 50/60Hz	100 100lm/W 120 120lm/W	C Clear F Frost	30 3000K 40 4000K 50 5000K



Teslights+

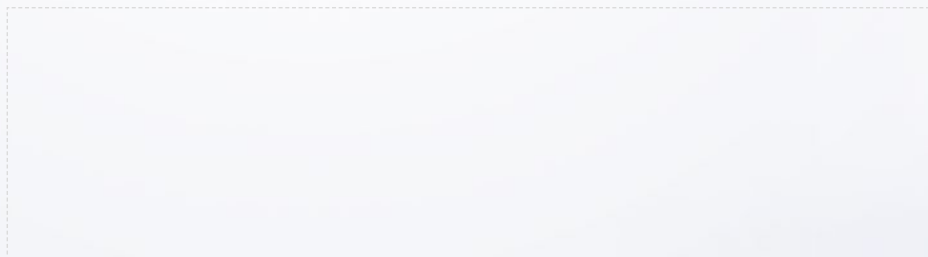

World Headquarters

3345 Industrial Dr.

Building #16

Santa Rosa, CA 95403, USA

+1 844 TESLITE

www.teslights.com - info@teslights.com